



TECHNICAL DATA SHEET

400-500-600-800 KVA UPS Systems



Cannon UPS Features

- ✓ True Online Double Conversion Topology
- ✓ 3 YEAR PARTS Warranty
- ✓ Input IGBT Rectifier and advanced Power Factor Control
- ✓ Inverter Transformer for trouble free output
- ✓ High Efficiency Online (>95%)
- ✓ ECO-MODE Function (Efficiency = 99%)
- ✓ Excellent Output voltage without Derating
- ✓ Digital Control
- ✓ Simplified and Distributed Parallel System
- ✓ High Power Density and Small Footprint
- ✓ Predictive Diagnosis for Battery Status
- ✓ Comprehensive Option Range

POWER	kVA	400	500	600	800
UPS type			ON LINE – Double Conversion ECO MODE - Stand by (selectable)		
Nominal output power (Cos Ø 0,8)	kVA	400	500	600	800
Nominal output power (Cos Ø 1,0)	kW	320	400	480	640
Efficiency (AC <input type="checkbox"/> AC) (ON LINE - Double Conversion)		%		> 94	
Efficiency (AC <input type="checkbox"/> AC) (Eco Mode)		%		> 98	
Heat dissipation at nominal load and voltage	kW	22,4	28,0	33,6	44
kcal/h (x1000)	19,2	24,0	28,8	38	
UPS ambient temperature		°C		0 <input type="checkbox"/> 40	
BATTERY ambient temperature		°C		0 <input type="checkbox"/> +25	
UPS storage temperature		°C		-10 <input type="checkbox"/> +70	
BATTERY storage temperature		°C		-10 <input type="checkbox"/> +60	
Relative humidity (non condensing)		%		< 95	
Altitude		m		< 1000 (above sea level)	
Power derating for altitude > 1000 m			According to "IEC62040-3", from 1000m to 2000m max with 1% derating for +100m		
Ventilation			Forced		
Requested cooling air volume	m3/h	3500	4000	4500	7000
Audible noise level (according EN 50091)		dB		< 60	
Standard battery type lead acid		n° cells		300	
Protection degree			IP 20		
Electromagnetic compatibility EMI			According "EN 62040-2" (CE marking)		
Safety			IEC EN 62040-1-1		
Test and performances			IEC EN 62040-3		
Paint			RAL9005		
Accessibility			Front and top access for service		
Installation			Also against wall and/or side-by-side		
Dimensions		mm		L=1990 P=990 H=1920 (400kVA) L=2440 P=990 H=2020 (500-600kVA) L=3640 P=990 H=1920 (800kVA)	
Weights (without	kg	1820	2220	2400	3600

battery)					
Static load (without battery)	kg/m2	924	917	992	1000
Design standard	"IEC EN 62040" "ISO 9000:2000"				
Free contact interface	Optional				
Serial communication interface	Standard: RS232 - USB Optional: RS485 (ModBus protocol)				
Parallel configuration (optional)	Up to 7+1 (redundant parallel) Up to 8 (power parallel)				

BLOCK DIAGRAM

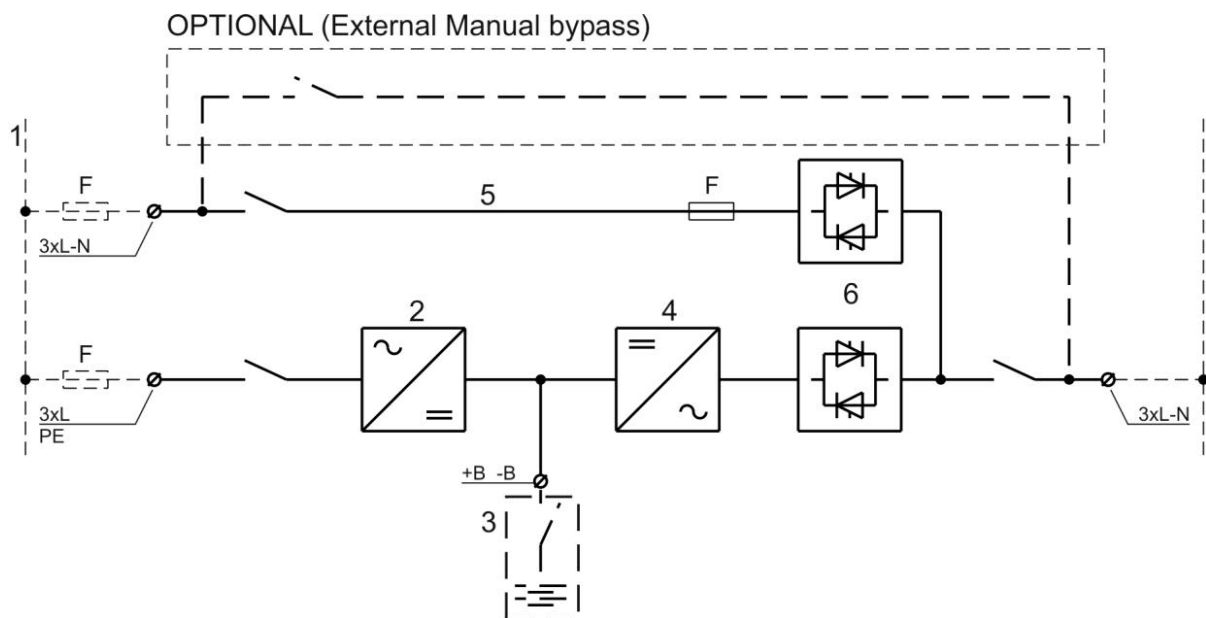

1. Input mains (separate for by-pass and rectifier)
2. Rectifier and battery charger
3. External battery
4. Inverter
5. Emergency line (by-pass)
6. Inverter (SSI) and by-pass (SSB) static switch

It is possible to install an external Manual Bypass connecting the auxiliary contact of status only.

DESCRIPTION:

- The UPS is designed following the criteria of low environmental impact.
- The quantity of the raw material used on the magnetic components and the number of semiconductors is minimized by the means of very advanced design criteria.
- The high overall efficiency minimizes the power consumption. The high efficiency and input power factor reduces the costs during the normal operation of the UPS.
- The inverter transformer prevents the direct feed-through of the battery potential into the critical load and provides a very high rejection ratio of the power supply disturbances (spikes, surges etc.).
- The UPS is equipped with a built in very advanced self diagnostic program indicating the problems and suggesting to the service people how to repair the faults.
- The unit input power factor and the low harmonic level of the input current (THDi < 3 %) allows reduction of the dimensions and costs of the installation in terms of size of the cables and the circuit breakers. Additionally, these features prevent over sizing generator sets installed upstream.
- Eco-mode function can be set. In this intelligent mode, the mains line is continuously being monitored in order to supply with high reliability the load by the same line. If the line is downgraded and required to be conditioned, inverter takes care of the load in less than 4msec. Once the load is accessed to properly operate in this way, in Eco-mode efficiency is considerably increased, allowing high energy saving.

POWER	kVA	400	500	600	800
Input		Three phase			
Nominal input voltage Range	Vac %	400 -20/+10			
Input frequency Range	Hz Hz	50-60 ±5			
Input power factor		> 0.99			
Input current THDi		%	< 3		
DC output voltage accuracy		%	±1		
Walk-in time duration		s	10		
DC output voltage ripple		% rms	1		
Battery recharging characteristic		IU (DIN 41773)			
Temperature voltage compensation		Optional			
Boost charge function (NiCd or lead open battery)		Configurable			
Maximum recharging current - at nominal load - with DCM function (max current)		60	80	80	120
		100	100	100	200
AC-DC converter type		PFC a IGBT			
Input protection		Fuses			
Nominal current absorbed from mains (at nominal load and battery charged)	A	500	620	750	1000
Maximum current absorbed from mains (at nom. load and max. recharging current)	A	560	700	820	1120

DESCRIPTION:

- The Input rectifier is designed to minimize the current harmonics rejected back into the input mains.
- The technology is based on a 6-IGBT matrix PFC, fully digitally controlled by a last generation 32 bit microcontroller.
- Large input mains variations are allowed without affecting the battery charge condition.
- The battery charge function is built into the same converter.
- The converter is designed to recharge the battery for extended time autonomies.
- By means of the DCM (Dynamic Charging Mode) function, batteries with very long autonomy can be managed without increasing total charging time. This is achieved by increasing the maximum battery charging current when the load doesn't draw the full power coming from the inverter.

BATTERY

POWER	kVA	400	500	600	800
Type standard (other on request)	Lead Sealed (Free maintenance)				
Number of cells	300				
Floating voltage at 25°C	680				
Minimum discharge voltage	496				
Power requested by inverter (at nominal load)	kW	336	420	500	672
Curr. req. from inverter (nominal load - minimum Vdc)	A	680	850	1020	1360
Battery protection (external to the UPS)	Wall mounted fuse box on request				
Battery test	Included as standard				

DESCRIPTION:

- The standard battery is composed of 300 sealed lead cells.
- The boost charge is available as an option for other battery types.
- Generator set mode available.
- The battery temperature compensation is available as an option.
- Long autonomy batteries can be used.
- Periodical automatic battery test available with adjustable time.

UPS OUTPUT: INVERTER

POWER	kVA	400	500	600	800
Inverter bridge	IGBT (High Frequency Comm.)				
Nominal output power (Cos Ø 0,8)	kVA	400	500	600	800
Nominal output power (Cos Ø 1,0)	kW	320	400	480	640
Efficiency (DC □ AC) %	> 96				
Permissible range of load power factor	See diagram				
Output	Three phase + Neutral				
Nominal output voltage (selectable)	Vac	380-400-415			
Output voltage stability	%	± 1			
- Static (balanced load)	%	± 2			
- Static (unbalanced load)	%	± 5			
- Dynamic (step load 0□100%□0)	ms	< 20			
- Output volt. recovery time (after step load)		Class 1			
- IEC 62040-3					
Phase angle	°	± 1			
- Balanced Load		± 1			
- 100% Unbalanced Load					
Output frequency	Hz	50 - 60			
Output frequency Stability	Hz	± 0,001			
- Free Running Quartz Oscillator	Hz	± 2 (other on request)			
- Inverter Sync. with Mains	Hz/s	1			
- Slew rate					
Nominal output current (@ 400 Vac output)					
- Cos □ 0,8		590	720	860	1180
- Cos □ 1		460	580	720	920
Overload capability	10 min >100%...125% 1 min >125%...150% 10 s =150%				
Short circuit current	A	690	870	1080	1380
Short circuit characteristic	Elect. Short circuit protection, current limited at 1.5 times nominal current. Automatic stop after 5 seconds				

Selectivity	Within ½ cycle (Fuse gl 20% In)	
Output waveform	Sinusoidal	
Output harmonic distortion - Linear Load - Non Linear Load (Crest factor 3:1) - IEC 62040-3	%	< 1 < 5 Fully compliant
Crest factor (non linear load)	3:1	

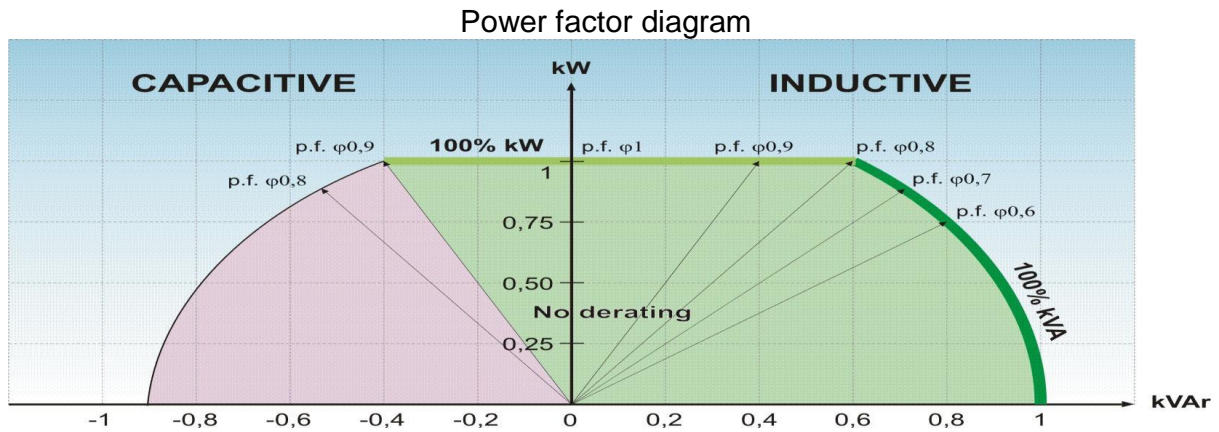

DESCRIPTION:

- The Inverter design is based on a full bridge 6-IGBT matrix, high frequency PWM, fully digitally controlled.
- The output voltage stability and the dynamic response are optimised.
- The selectivity in case of short-circuit is very high and the recovery of the voltage is digitally controlled (Soft Short Recovery Loop “SSRL”).

UPS OUTPUT: BYPASS

Automatic static by-pass		Electronic thyristor switch
Protection		Fuses
Bypass	Vac	Threephase + Neutral
Nominal voltage Range	Vac %	380-400-415 ±10
Nominal frequency Range	Hz %	50-60 ± (1□5) configurable
Transfer mode		Without break
Transfer inverter → automatic bypass		In case of: - Static Switch test - Inverter test - Inverter not operating - Battery end of discharge
Retransfer Automatic bypass → inverter		- Automatic - Block on bypass after 6 switches within 2 minutes, reset by front panel
Overload capability	%	-150 % Continuously -1000 % For 1 Cycle
Manual by-pass for maintenance		Option (external): - Electronically controlled - No break
Back Feed protection		Optional

DESCRIPTION:

- The electronic control avoids the risks of power interruption in case of transfer from inverter to by-pass and vice-versa.
- It is possible to install an external maintenance bypass, connecting the external auxiliary signal contact only.

PARALLEL

Automatic parallel configuration for redundancy/capacity		Up to 7+1 (redundant parallel) Up to 8 (power parallel)
Basic parallel configuration		Redundant N+1
Connection type		CAN Bus Loop
Share Accuracy (max unbalancement)	%	10
Maximum distance between two units	m	10 (more on request)
Overload capability		N x 200% for 100 ms N x 125% for 10 min
Automatic by-pass		On each unit
Manual by-pass		Option (external)

DESCRIPTION:

- The parallel UPS configuration is provided with control for operation both redundant and capacity increasing.
- The parallel control is fully digital and acts on both active and reactive power on each output phase, allowing an accurate load current sharing among the UPSs', even during transient conditions.
- Parallel control is distributed (not centralised control, but on each UPS microcontroller) and communication among units uses CAN BUS connection loop, providing a highly reliable system without "single points of failure".
- Extremely simple parallel control and interconnections make easy installations and on field upgrading, adding new units to the system according to the customer's needs.
- It is possible to install an external maintenance bypass, connecting the external auxiliary signal contact only (one for each UPS).

MONITORING

LOCAL ON FRONT PANEL

- Synoptic showing: power flow, circuit breaker status and alarms
- LCD display
- Keyboard

PC (Windows OS):

- **Through UPS Monitor software**
 - Connection point-point UPS-PC via RS232
 - Remote connection through modem
 - All the local indications, alarms and measures
 - Basic troubleshooting
 - History Events

RELAY CARD:

- **SRC card free relay contact**
 - Eight signals Alarms/Statuses are available remote connections:
 - Free relay contact

Relay	Description	Alarms / Status
RL1	Common alarm	A30
RL2	Mains failure	A01
RL3	Battery end of discharge	A09
RL4	Inverter not OK	A13
RL5	Bypass feeding load	A16
RL6	Rectifier OK	S01
RL7	Inverter feeding load	S04
RL8	Bypass OK	S06

REMOTE:

- **SNMP adapter. Optional**
 - LAN, WAN , web server features and monitoring by a browser.
 - UPS operation monitoring and servers management.
- **RS485 interface board. Optional**
 - ModBus protocol
 - UPS operation monitoring
- **Remote Panel. Optional**
 - 4 Alarms/Statuses monitoring and common alarm

OPTIONS

1. BATTERY TEMPERATURE VOLTAGE COMPENSATION
2. INSULATION TRANSFORMER ON BY-PASS
3. VOLTAGE ADAPTATION AUTO-TRANSFORMERS
4. FREE CONTACTS RELAY CARD
5. SERIAL INTERFACE RS-485 (MOD-BUS protocol)
6. SNMP ADAPTER
7. MODEM
8. PARALLEL CARD INTERFACE
9. EXTERNAL BATTERY CABINET
10. WALL MOUNTED FUSED SWITCH BOX
11. IN/OUT TOP CABLE ENTRY
12. SPECIAL PAINT
13. MCB EXTERNAL CABINET